

THREE FLAVOR FREE-STANDING SOFT ICE CREAM MACHINE



ISI-203SN (P)



Features



SIMPLICITY



PERFORMANCE



RELIABILITY



EXCELLENT TASTE



Mix Hopper

2.51 gallon x 2EA; maintains the temperature of mix under 41°F in Auto & Standby modes



Freezing Cylinder

0.72 gallon x 2EA



Intelligent Control System

Microprocessor-based control system to ensure high quality soft serve ice cream



Two flavors, one twist



Dimensions

Dimensions	Net	Ship
Width	23" (590 mm)	24" (615 mm)
Depth	35" (900 mm)	37" (930 mm)
Height	60" (1,515 mm)	66" (1,685 mm)
Weight	586 lbs (266 kg)	654 lbs (296.5 kg)

Certification



- 1202 W. Struck Ave, Orange, CA 92867
- TEL : 714-215-4864
- WEB : www.icetroamerica.com
- 6432 Warren Dr., Norcross, GA 30093
- TEL : 470-567-8603
- Email : icetro@icetroamerica.com

THREE FLAVOR STAND TYPE SOFT ICE CREAM MACHINE

Dimension – Unit : mm (inch)

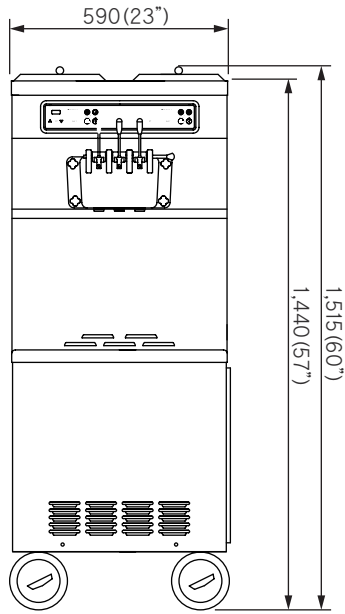

FRONT

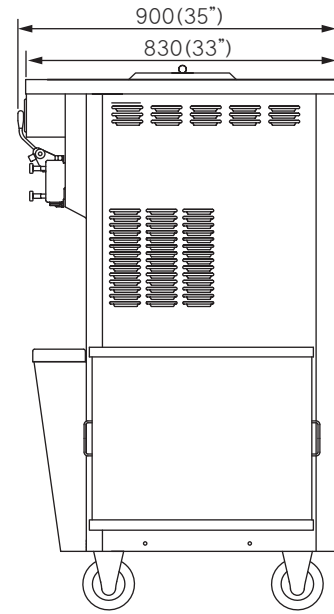

RIGHT SIDE

Specification

Model	Mix Hopper Capacity	Cylinder Capacity	Consecutive Dispensing	Dasher Motor	Max. Production	First Dispense
ISI-203SN	2.51 gal. (9.5 liter) x 2EA	0.72 gal. (2.7 liter)] x 2EA	12~14 cups (100 cc/3.0 oz)	1.0 HP x 2EA	5.63 gal/hr	11 min.
	Cylinder Compressor	Power Consumption	Mix Hopper Compressor	Cooling System	Electrical Option	
	1 HP x 2EA (R-404A)	4,390 W	0.35 HP (R-134A)	Air-Cooled	208~230V/60Hz/3PH	

※ Production Capacity may vary depending on ambient temperature.

Detail View



Simple & easy to access control system on the front touch panel



Removeable air filter at the bottom of the right side



Automatically detects MIX LOW by sensor

※ Design and Specification are subject to change without notice.



• 1202 W. Struck Ave, Orange, CA 92867 6432 Warren Dr., Norcross, GA 30093
 • TEL : 714-215-4864 TEL : 470-567-8603
 • WEB : www.icetroamerica.com Email : icetro@icetroamerica.com

Revised: 4/24/2024