

BROASTER
EQUIPMENT

Broaster® E-Series Pressure Fryer - 18G



Featured Innovations

- **Highest Energy Efficiency in Pressure Fryer Category** – gas-fueled E-Series 18G boasts the highest-level energy efficiency offering a 50,000 BTU/HR efficient burner system, which as compared to the current Broaster 1800 model is greater than 23% less gas usage.
Ready for Energy Star application once EPA has established standards for pressure fryers.
- **One-touch Cook Cycle** – cycle starts automatically with lid closure, no additional labor needed.
- **Automatic Controlled Pressure Release** – end of cook cycle automatically triggers release of pressure within the cooking well.
- **More Production Capacity** – elimination of a long manual oil filtration and an enhanced burner system for faster heat recovery means more fry time.
- **Advanced Filtering Technology** –new on-board integrated filtration system with stainless steel filter pan.
- **On Board Oil Replenishment** –ability to top fryer oil off easily based on operator need.
- **Automatic Oil Filtration Between Cook Cycles** – unit automatically begins a quick filtration cycle after each cook cycle. Duration of the filter cycle can be adjusted to Operator preferences in SmartTouch controller.
- **Bulk Oil Handling** – can be easily connected to bulk oil input and discharge systems to eliminate employee handling of oil.
- **Advanced Microprocessor Controller** – easy-to-use, touch screen interface reduces training time for new employees. Bilingual interface included.



TESTED TO ANSI Z83.11 – CSA 1.8 – 2016
TESTED TO ANSI / NSF 4

Safety Features

Triple-redundant safety system is featured consisting of a chrome plated relief valve, a stainless steel splash guard and a single action patented cam lock cover system.

To ensure operator convenience and safety, unit features a pressure activated cover-locking mechanism and the SmartTouch Controller which integrates an automatic pressure regulator valve, exhaust valve, and drain valve interlock.

Standard setup includes on-board oil replenishment for easy oil addition.

Available bulk oil handling connections eliminate the need for employees to handle heavy oil jugs and dispose of hot oil.

Unique stainless steel basket with a ratchet-style removable basket handle allows easier unloading of product.

Broaster® E-Series Pressure Fryer - 18G

FRONT VIEW

SIDE VIEW

TOP VIEW

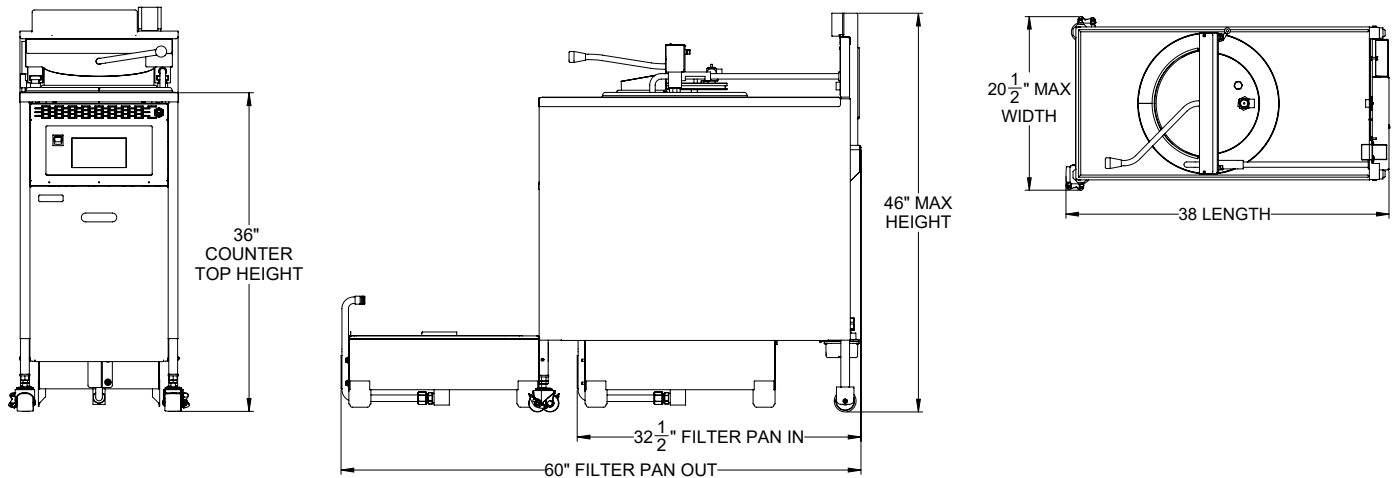

Dimensions

Model	Fresh Chicken Capacity	Cooking Oil Capacity	Operating Pressure	Overall Dimensions			Counter Height	Net/Ship Weight
				W	D	H		
E-Series 18	14 lbs./load	42 lbs.	12 - 14 P.S.I.	20.5"	38"	46"	36" (915 mm)	300/340 lbs.
				(521 mm)	(965 mm)	(1169 mm)		

Additional Features

Specifically designed for high volume production, cooks up to 32 pieces of fresh bone-in chicken per load in as little as 11-12 minutes.

Unique Auto Comp feature automatically adjusts cooking time to accommodate for varying sizes and temperatures of loads.

Perfect for all your fried chicken cooking needs, including hand breaded tenders.

Primary construction is of stainless steel built on black powder-coated steel frame with front and rear casters for mobility and ease of cleaning.

Proven round cooking well design engineered for more uniform heat distribution, durability and efficiency; no cold spots or corners. Large capacity provides more room for product, minimizes sticking and produces delicious, superior quality food.

Fully welded cooking well is made from durable 300 series stainless steel.

Energy Requirements

50,000 BTU/hr
1 phase, 120 volt, 60 hz, 15 amp service
Attached 6 ft. cord with plug



Mainfold Pressure:
Natural Gas: 3.5 in-wc
LP Gas: 10 in-wc

Ready for Energy Star application once the EPA has established standards for pressure fryers.

BROASTER® E-SERIES 18